

HYDRAULIC AND RIGID RESTRAINTS

**FRONEK ANCHOR/DARLING ENTERPRISES, INC.
86 DORIS RAY COURT
LACONIA, NH 03246
INFO@FRONEKGRP.COM
PH: 713-731-0030
FAX: 713-731-8640**

	PAGES
HYDRAULIC SNUBBERS.....	R1-R4
SWAY STRUT ASSEMBLIES.....	R5-R6

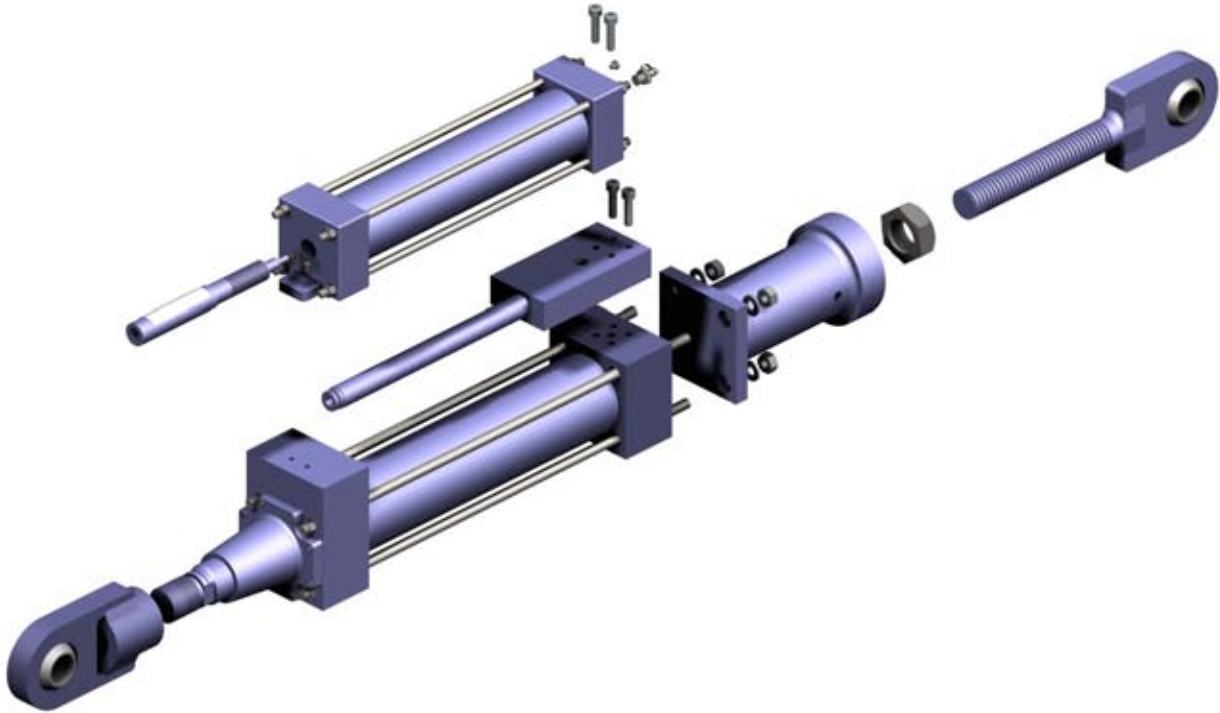

HYDRAULIC SNUBBER HYDRAULIC SNUBBER

SHORT STRUT FIG.510AD ADJUSTABLE STRUT FIG.511AD

The style "AD" Hydraulic Shock Arrestor is a manifold design hydraulic component consisting of a high pressure main cylinder, a flow control section which contains dual stage velocity sensitive poppet valves, and a spring energize reservoir.

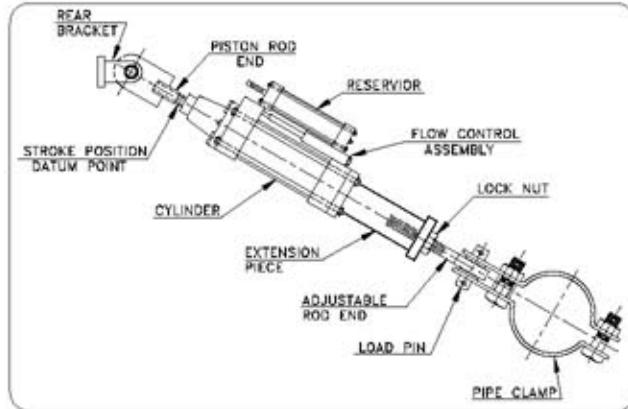

RECOMMENDED APPLICATION

Used for the control and protection of piping and equipment subject to shock (impulse) loading and seismic (cyclic) conditions. Its use transfers any imposed forces on the piping or equipment directly to the building structure at the instant of shock occurrence, while at all other times allowing free unrestricted movement through its normal operating range.

BASIC OPERATION

The piston rod is free to move in either direction with no restrictions to the fluid flow for all piston velocities up to the activation velocity. At activation velocity the poppet valve, internal to the snubber, closes. Closure of the poppet in either tension or compression greatly reduces the fluid flow through grooves in the poppet at rated design capacity of the unit is termed the " bleed rate". When the applied velocity of the unit becomes zero the poppet valve opens once again, allowing free piston movement.

STANDARD DESIGN FEATURES

- Piping and/or equipment movement is controlled by tamperproof dual stage flow control poppets designed with self-cleaning orifices.
- Furnished as a complete, compact and efficient unit, ready for immediate use.
- Manifold configuration requiring no external piping.
- Spherical, self-aligning ball bushings allow for $\pm 5^\circ$ of angular motion or misalignment.
- Stable premium grade, antiwear hydraulic fluid.
- Pressurized hydraulic reservoir allows mounting in any spatial orientation.
- Virtually no resistance to normal thermal movements of the piping.

- Large restraining forces compared to size.
- Functions in restraining tension and compression loads.
- Designed for continuous operation up to 200°F with brief transients to a maximum of 300°F.
- Stroke position is measured from a machined groove located at the piston rod wrench flats.
- Fluid Level in the unit, thereby eliminating estimate of reserve fluid level.

OPTIONAL DESIGN FEATURES

- Remote Reservoir Mounting - The snubber's pressurized reservoir can be remotely mounted for inaccessible locations.
- Integral Relief Valve- A non-adjustable valve, which is factory preset at 133%, or 200% of rated load.
- Protective Boot- Installed over piston rod for protection against corrosive or outdoor environments.
- Rigid Stud Application- When no thermal growth is anticipated after lock-up, an optional poppet valve, without bleed, can be furnished. Must be ordered with optional integral relief valve.

SIZE RANGE

Seven sizes with cylinder bores of 1 1/2" to 8" and with normal load ratings from 3000 to 130,000 pounds. All are made with integral pressurized reservoirs in 6", 12" or 18" strokes.

SIZE SELECTION

The selection of size depends on the anticipated force and thermal movement of the protected piping or equipment. It is recommended that the selected cylinder stroke be a minimum of the anticipated thermal movement, plus 20%.

FACTORY PRE-SET

The units are shipped from the factory complete, tested, reservoir filled to capacity and piston rod preset to mate with pin to pin installation dimension.

To determine factory pre-set dimension perform the following calculations.

COMPRESSION STROKE:

$$\text{Pre-Set} = \text{Pre-Set Max.} - \left(\frac{\text{Cylinder Stroke} - \text{Thermal Mvt.}}{2} \right)$$

$$H = \text{Hmin.} + \left(\frac{\text{Cylinder Stroke} + \text{Thermal Mvt.}}{2} \right)$$

TENSION STROKE:

$$\text{Pre-Set} = \text{Pre-Set Min.} + \left(\frac{\text{Cylinder Stroke} - \text{Thermal Mvt.}}{2} \right)$$

$$H = \text{Hmin.} + \left(\frac{\text{Cylinder Stroke} - \text{Thermal Mvt.}}{2} \right)$$

HYDRAULIC SNUBBERS: SHORT STRUT FIG.510AD, ADJUSTABLE STRUT FIG.511AD

FIG. 510AD SHORT STRUT HYDRAULIC SNUBBER

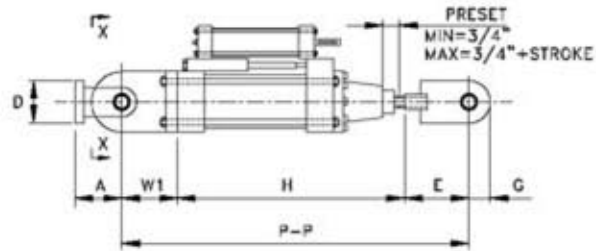

SECTION & DETAILS FOR FIG. 510AD & FIG. 511AD

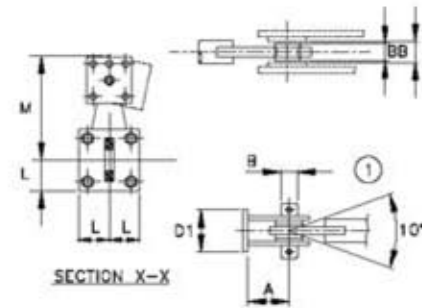
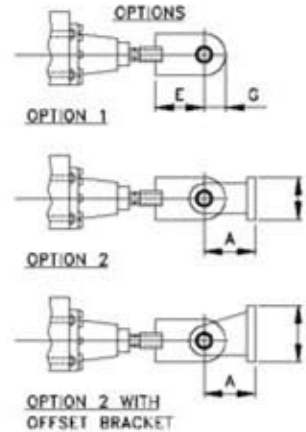
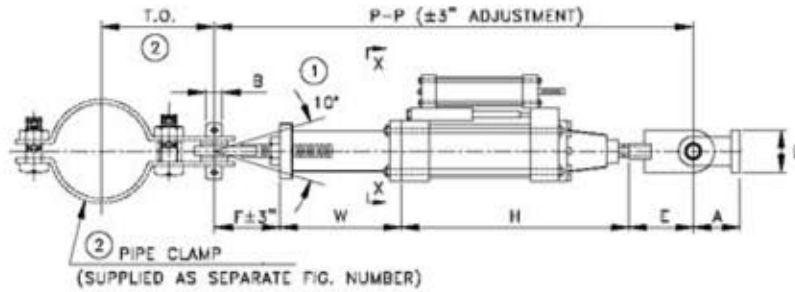

FIG. 511AD ADJUSTABLE STRUT HYDRAULIC SNUBBER



- NOTES:**
- ① LOAD MUST BE APPLIED INSIDE OF A 10° CONE LINE OF ACTION.
 - ② CONTACT FCI FOR PIPE CLAMP DESIGN.

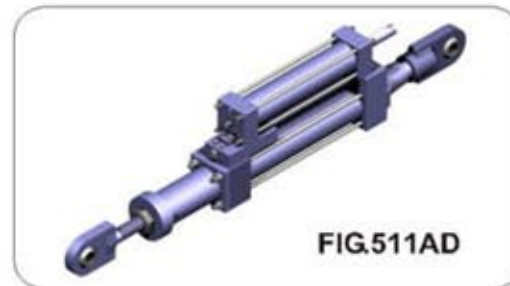

FIG. 510AD - SHORT STRUT HYDRAULIC SNUBBER

CYLINDER		APPROX WEIGHT (1)	H MIN (2)	P-P MIN. (2)	LOAD RATING (KIPS)	A	B	D	D1	E	G	L	M	W1	S	BB
SIZE	STROKE															
1 1/2	6	35	16	21	3	2	3/4	2 1/2	2 3/4	3	1 1/16	1 1/4	5	2	3/4	0.656
	12	42	22	27												
	18	50	28	33												
2 1/2	6	70	16 1/2	23 1/4	10	2 1/2	1	3	3 1/2	3 3/4	1 1/2	1 3/4	6	3	1	0.875
	12	83	22 1/2	29 1/4												
	18	96	28 1/2	35 1/4												
3 1/4	6	125	17 3/8	27 1/8	20	4	1 1/2	5	4 3/4	5 1/2	2 1/2	2 1/4	7 3/8	4 1/4	1 1/2	1.312
	12	145	23 3/8	33 1/8												
	18	165	29 3/8	39 1/8												
4	6	155	17 3/4	28 1/2	30	4	1 1/2	5	4 3/4	6 1/2	2 1/2	2 1/2	8 1/2	4 1/4	1 1/2	1.312
	12	180	23 3/4	34 1/2												
	18	205	29 3/4	40 1/2												
5	6	255	18 1/4	31 3/4	50	5 1/2	2	7	6	8	3 1/2	3 1/4	10 1/4	5 1/2	1 7/8	1.75
	12	290	24 1/4	37 3/4												
	18	325	30 1/4	43 3/4												
6	6	410	19 1/2	33 3/4	70	6	2 1/4	7	6 1/2	8 1/2	4	3 3/4	11 7/8	5 3/4	2 1/4	1.968
	12	465	25 1/2	39 3/4												
	18	520	31 1/2	45 3/4												
8	6	805	21 3/16	41 7/16	130	8 1/2	3	10	10	12 1/2	5 1/2	4 3/4	16	7 3/4	2 7/8	2.625
	12	890	27 3/16	47 7/16												
	18	975	33 3/16	53 7/16												

FIG. 511AD - ADJUSTABLE STRUT HYDRAULIC SNUBBER

CYLINDER		APPROX WEIGHT (1)	P-P		F	W MIN
SIZE	STROKE		MIN	(4) MAX		
1 1/2	6	40	32 3/4	100	6 1/4	7 1/2
	12	47	38 3/4	100		
	18	54	44 3/4	100		
2 1/2	6	75	36 1/4	120	7 1/4	8 3/4
	12	90	42 1/4	120		
	18	105	48 1/4	120		
3 1/4	6	130	41 5/8	120	9 1/2	9 1/4
	12	150	47 5/8	120		
	18	170	53 5/8	120		
4	6	200	44 1/8	120	10 1/8	9 3/4
	12	225	50 1/8	120		
	18	250	56 1/8	120		
5	6	330	49 1/2	120	12 1/2	10 3/4
	12	365	55 1/2	120		
	18	400	61 1/2	120		
6	6	530	53 3/8	120	13 3/4	11 5/8
	12	590	59 3/8	120		
	18	645	65 3/8	120		
8	6	1050	62 11/16	120	16 1/4	13 3/8
	12	1140	68 11/16	120		
	18	1225	74 11/16	120		

(FOR DIMENSIONS NOT SHOWN, SEE FIG.510AD TABLE ABOVE)

NOTES:	(1) WEIGHTS IN LBS. FOR OPTION 1.
	(2) FULLY RETRACTED.
	(3) ALL DIMENSIONS IN INCHES.
	(4) CONTACT FCI FOR LONGER UNITS.

PISTON ROD SETTING:

The factory will preset and clamp the piston rod at the proper cold installing stroke position. Unless specified otherwise, this setting will position the piston so that its calculated thermal movement will straddle the mid-stroke position of the unit, giving equal reserve at each end of the stroke. See installation instructions to determine or change piston rod setting.

ORDERING:

Specify FIG.No., option, cylinder size & stroke, thermal movement and direction (tension or compression), preset, overall assembly length (P-P), customer mark number (if any), pipe clamp data (pipe size, material, temperature, t.o.)

Specify and describe any additional optional features.

INSTALLATION:

STEP 1: Check that front paddle is securely fastened to the piston rod. If loose, tighten the connection by means of holding the piston rod on the wrench flats provided and tightening the paddle against it. DO NOT use a pipe wrench on the chromed shaft of the rod. Try to minimize the amount of rotation of the piston rod within the cylinder to prevent possible scoring or seal damage. Torque the connection to between 15 and 25 ft-lbs for all cylinder sizes.

STEP 2: If required, attached the extension piece to the rear of the cylinder or check the torque of the nuts if already assembled. Note: When tightening the extension piece nuts, use a wrench on the tie-rod nuts at the piston rod end of the cylinder to apply a counter-torque. If this procedure is not followed, the cylinder tie rods will loosen. Torque the nuts to the valves listed in the chart below.

CYCL SIZE (KIPS)	BORE SIZES (INCHES)	THREAD (UNC)	TORQUE (FT-LBS)
3	1.5	3/8 - 16	30
10	2.5	1/2 - 13	60
20	3.25	5/8 - 11	100
30	4.0	5/8 - 11	100
50	5.0	7/8 - 9	230
70	6.0	1 - 8	300
130	8.0	1-1/4 - 7	700
200	10.0	1-3/4 - 5	1500

STEP 3: Consult the hanger detail to determine the required as-built cold pin-to-pin dimension. The extension piece comes equipped with a threaded rod connection to accommodate field length adjustments. Sight holes are provided in the extension pipe to ensure proper thread engagement. The male threads must be visible through these holes for proper load carrying capability. A lock nut is provided to freeze the adjustment. Torque to 50 ft-lbs for all cylinder sizes. For hanger assemblies not equipped with extension pieces (FIG. 510 AD) field length adjustment must be accomplished by repositioning the supporting structures or the cylinder cold set. Approval of new cold set by Shaw FCI should be obtained. Refer to Section E for this procedure.

STEP 4: Orient each end attachment or pipe clamp to ensure that the available alignment provided by the ball bushings is within the allowed 10 degree cone of action.

STEP 5: Hoist the assembly into place. Cylinders equipped with remote reservoirs can have the reservoir de-coupled at this time provided it will not be necessary to reposition the cylinder piston rod during installation. Reconnect the reservoir after the assembly has been pinned in place. NOTE: Due to the pressurized design of Shaw FCI reservoirs, there is no concern for orientation as it will function properly in any spatial orientation. It is recommended that the elevation of the remote reservoir be at or above that of the main cylinder.

The load pins provided with the assembly fit into close toleranced holes for which care must be exercised during installation. Removal and insertion should be accomplished carefully and without undue force. Spacer washers are provided to ensure proper function of the ball bushing alignment feature. The load pins are provided with cotter pins which must be securely installed. Any relocation of the assembly to clear an interference should be brought to the attention of the project engineer. Adherence to project tolerance guidelines should be observed.

STEP 6: Remove and discard the piston rod locking clamp (if supplied). Recheck all bolted connections. For units supplied with remote reservoirs, ensure that proper connections are made and that the flexible hose is free from kinks. Visually examine the entire assembly for erection damage, paying particular attention to the chromed surface of the piston rod. This completes the installation of the assembly.

Sway Strut Assembly FIG.515

SERVICE: Used to restrain movement of piping in one direction while allowing for movement due to thermal expansion in other directions. Effective for either tensile or compressive force. Self-aligning bushings permit ±5 degrees misalignment or angular motion.

ORDERING: Specify figure number, assembly size, name, nominal pipe size or special O.D., clamp material (alloy or carbon steel) and dimension C-C.

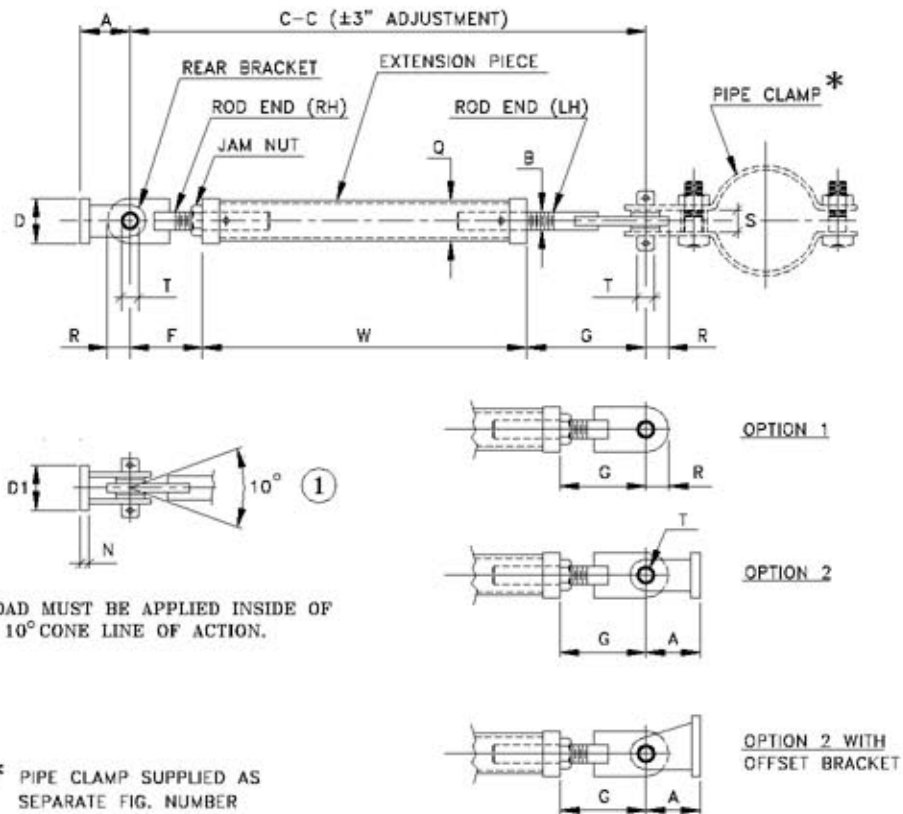

Loads (lbs) • Dimensions (inches)

SIZE	① LOAD	A	B	C-C		D	D1	F	G	N	Q	R	S	T	W MIN
				MAX	MIN										
0	2710	2	3/4	120	17	2 1/2	2 3/4	4 3/4	4	1/2	1 7/8	1	1 1/4	3/4	8 1/4
1	8000	2 1/2	1 1/4	120	20 1/2	3	3 1/2	6 1/4	5	3/4	2 3/8	1 1/2	1 1/2	1	9 1/4
2	11630	2 1/2	1 1/2	120	21 1/2	3	3 1/2	6 1/2	5	3/4	2 7/8	1 1/2	1 1/2	1	10
3	15700	4	1 3/4	120	26 1/4	5	4 3/4	8 3/4	7	1	3 1/2	2 1/2	2	1 1/2	10 1/2
4	20700	4	2	120	26	5	4 3/4	8	7	1	3 1/2	2 1/2	2	1 1/2	11
5	27200	4	2 1/4	120	28 1/8	5	4 3/4	8 5/8	7 1/2	1	3 1/2	2 1/2	2	1 1/2	12
6	33500	5 1/2	2 1/2	120	32 3/4	7	6	10 3/4	9 1/2	1 1/2	4 1/2	3 1/2	2 3/8	2	12 1/2
7	50600	5 1/2	3	120	34	7	6	11	9 1/2	1 1/2	4 1/2	3 1/2	2 3/8	2	13 1/2
8	71600	6	3 1/2	120	37 1/4	7	6 1/2	12 1/4	10 1/2	1 1/2	5 9/16	4	2 3/4	2 1/4	14 1/2
9	95500	8 1/2	4	120	41 1/2	10	10	14	12	2	5 9/16	5	3 7/8	3	15 1/2
10	123200	8 1/2	4 1/2	120	43 3/4	10	10	14 3/4	12 1/2	2	6 5/8	5 1/2	3 7/8	3	16 1/2

Adjustable Sway Strut Assembly

FIG.516

SERVICE: Used to restrain movement of piping in one direction while allowing for movement due to thermal expansion in other directions. Effective for either tensile or compressive force. Self-aligning bushings permit ± 5 degrees misalignment or angular motion.

ORDERING: Specify figure number, assembly size, name and dimension C-C.

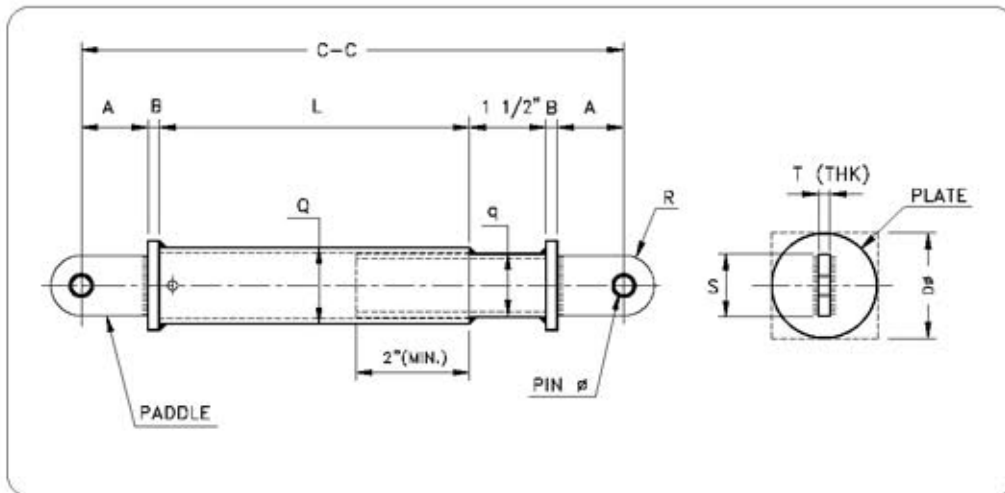
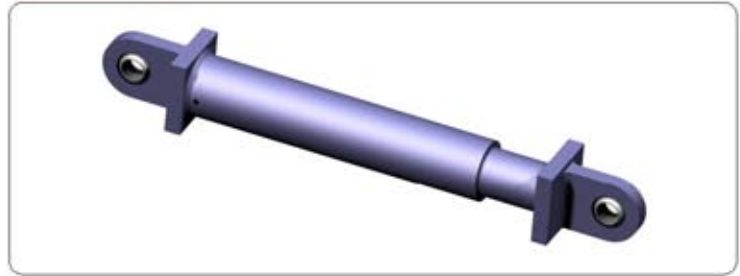

Loads (lbs) • Dimensions (inches)

SIZE	MAX LOAD LB	A	B	C-C		L-L		PIN (dia.)	D (dia.)	Q (dia.)	q (dia.)	R	S	T	WEIGHT (APPROX.)	
				MIN	MAX	MIN	MAX								C-C MIN	C-C MAX
				LB	LB	LB	LB									
0	2710	1 5/8	3/8	9	17	3 1/2	11 1/2	3/4	2 1/2	2.375	1.900	1	2	5/8	6	9.3
1	8000	2 1/4	3/4	11	21 1/2	3 1/2	14	1	3	2.375	1.900	1 1/2	3	3/4	9.9	14.3
2	11630	2 1/4	3/4	11	22	3 1/2	14 1/2	1	3 1/2	2.875	2.375	1 1/2	3	3/4	12.2	19.2
3	15700	3 1/2	3/4	13 1/2	28 1/2	3 1/2	18 1/2	1 1/2	4 1/2	3.500	2.875	2 1/2	5	1 1/8	28.3	41.1
4	20700	3 1/4	1	13 1/2	26 5/8	3 1/2	16 5/8	1 1/2	5	4.500	3.500	2 1/2	5	1 1/8	35.2	51.6